

2

1

ELECTRICAL CHARACTERISTICS

CENTER FREQUENCY: 800 MHz
 VSWR BANDWIDTH: 200 MHz MIN
 RETURN LOSS: 1.5:1 MAX
 INSERTION LOSS: 1.0 dB MAX @ FO
 PASSBAND VARIATION: 0.5 dBc MAX
 REJECTION:
 50 dBc MIN @ FO±700 MHz
 60 dBc MIN @ FO±900 MHz
 60 dBc MIN @ FO±1000 MHz
 60 dBc MIN ULTIMATE REJECTION TO 2.7XFO
 IMPEDANCE: 50 OHMS IN/OUT

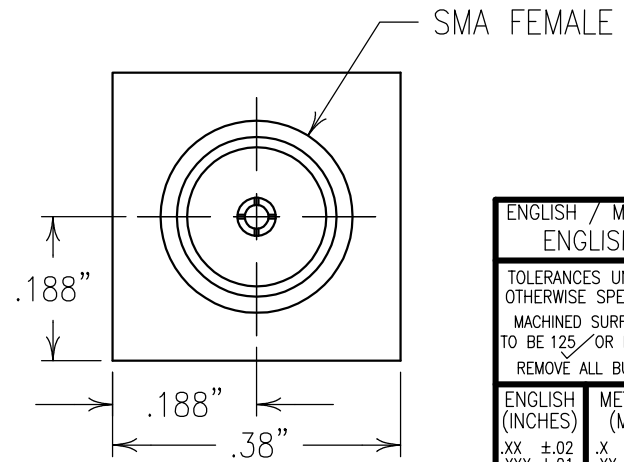
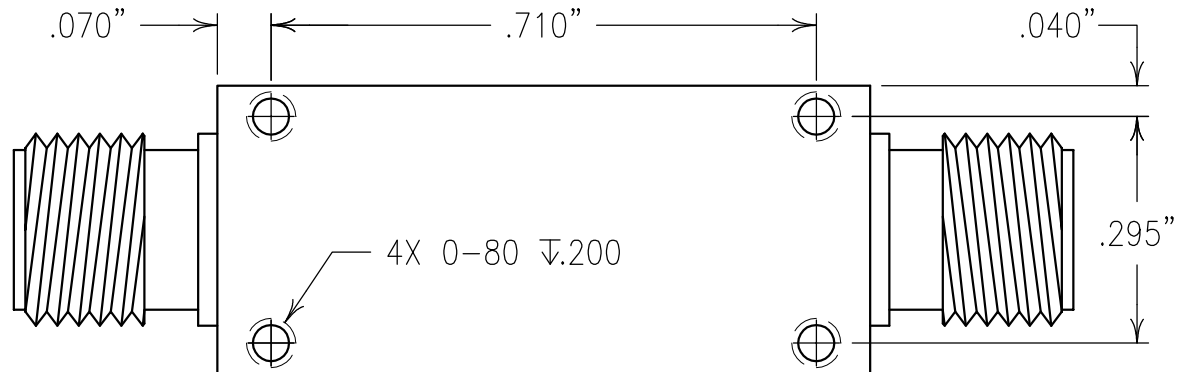
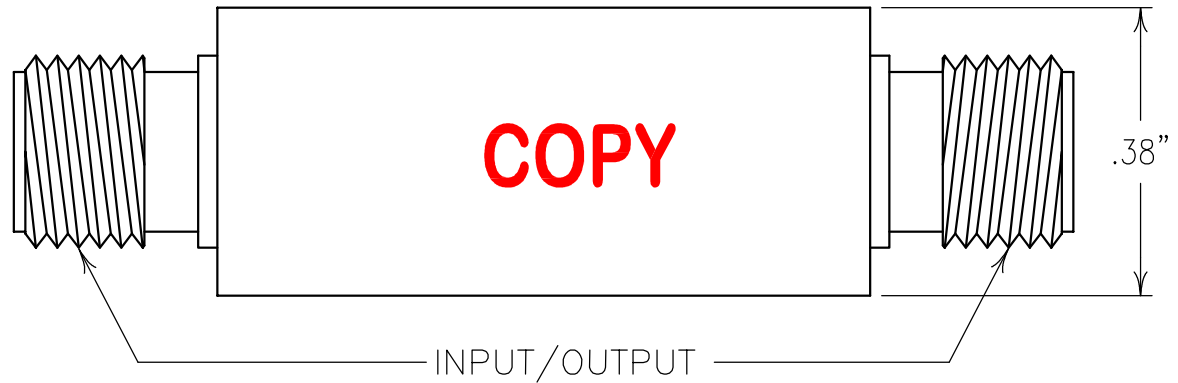
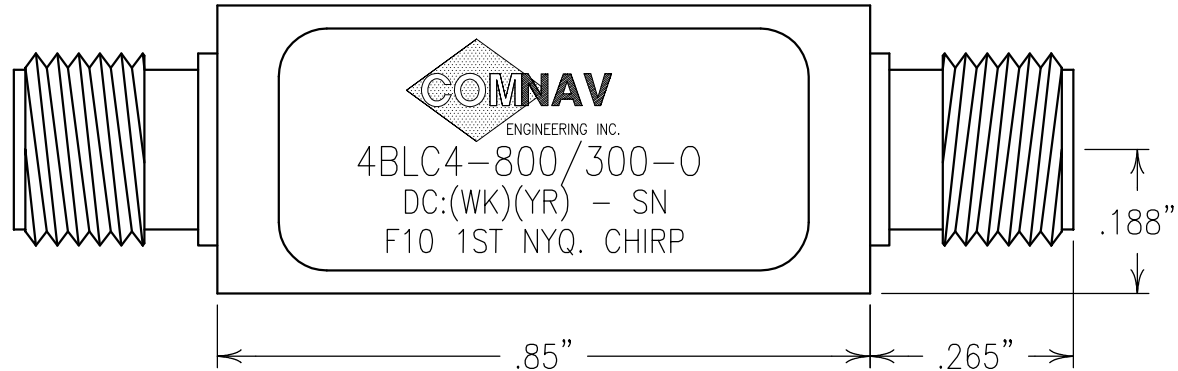

ENGLISH / METRIC	
ENGLISH	
TOLERANCES UNLESS OTHERWISE SPECIFIED	
MACHINED SURFACES TO BE 125 OR BETTER	
REMOVE ALL BURRS	
ENGLISH (INCHES)	METRIC (MM)
.XX ±.02	.X ±.4
.XXX ±.01	.XX ±.25
ANGLES ± 0° 30'	

NOTES:
 FILTER IS ROHS COMPLIANT.



CHECKED BY					
DRAWN BY	PBF				
ENGINEER	KJR	II	09OCT09	KJR	DEV. INI. ISS. PER 3137
SCALE	4:1	REV	DATE	BY	DCN No. REMARKS

APPLIC:	LC FILTER	
DATE	TITLE:	SHEET OF
15OCT09	4BLC4-800/300-0	1 1

MATERIAL: LID: NICKEL/SILVER	DRAWING No.
BASE: ALUMINUM 6061-T6	
FINISH: LID: NONE	OL1042
BASE: SILVER MATTE OVER COPPER WITH TARNA-BAN MILSPEC QQS-365	

Confidential and Proprietary information of ComNav Engineering Inc. Do Not Duplicate or Use Without Permission. ComNav Engineering Inc. claims Copyright in this document as of the Creation, last revision, and last updated dates. All Rights Reserved.

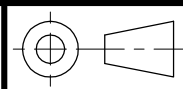

A